

Today
Friday
Monday

Ch 20 2nd ½ DC Circuits
Review for test 2
Test 2

HW11redo HW 13
HW12redo HW14

20.1 Electric Power

- Energy transfer from voltage to charged particles
- Energy transfer from the charged particles to the wire
- Steady State equivalence

- **Example 1:** Back to our light bulb. Again, the filament of our light bulb has a resistance of 580 Ω and it is screwed into a ceiling light socket, with a voltage of 120V across the terminals. What is its Wattage?

20.2 Alternating Current - Skip for now. Not on Test. We'll come back to when it's more appropriate.

Multi-component circuits

Introduction

Negligible Wire resistance in a circuit

20.3 Series Wiring

- Current
- Voltage
 - Kirchhoff's Loop Rule
- Resistance
 - effective or equivalent resistance

Example 2: Say you have three resistors in series across a 24-V battery. If the first one has a potential drop of 10V, the second has a drop of 12V, and the third has a resistance of 200 Ω:

- A) What is the current passing through the circuit?
- B) What are the resistances of the other two?
- C) What is the power dissipated in each?

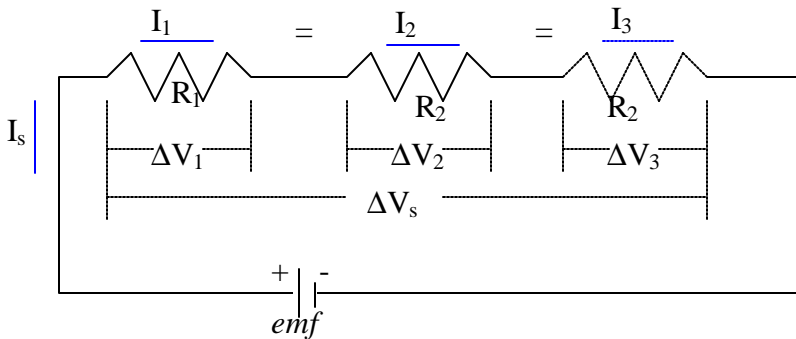

Quantities

- 1: $\Delta V_1 = 10\text{Volts}$, $R_1 = ?$, $I_1 = ?$ $P_1 = ?$
- 2: $\Delta V_2 = 12\text{Volts}$, $R_2 = ?$, $I_2 = ?$ $P_2 = ?$
- 3: $\Delta V_3 = ?$, $R_3 = 200\Omega$, $I_3 = ?$ $P_3 = ?$
- S: $\Delta V_s = |emf| = 24\text{V}$, $R_s = ?$, $I_s = ?$

20.4 Parallel Wiring

- How do the Resistances, Currents, and Voltages relate?
 - Current
 - Kirchhoff's Junction Rule
 - Voltage

- Resistance
 - Extend to any number of parallel resistors.

- **Example 3:** Warning – if the units are up-sided-down, so is the number. Three speakers are connected in parallel across the terminals of an amplifier. If one has a resistance of 16 Ω and each of the other two have 8 Ω, what is the equivalent resistance of the combo?

20.5 Circuits wired partially in series and Partially in Parallel

- **Parallel:** $\frac{1}{R_p} \equiv \frac{1}{R_1} + \frac{1}{R_2} + \dots$
- **Series:** $R_s = R_1 + R_2 \dots$

- **Example 4:** Determine the Equivalent Resistance of the pictured Circuit.

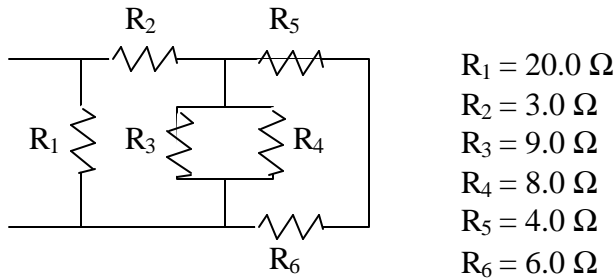

HW 14

22. A cigarette lighter in a car is a resistor that, when activated, is connected across the 12-V battery. Suppose a lighter dissipates 33W of power. Find (a) the resistance of the lighter and (b) the current that the battery delivers to the lighter.

43. Three resistors, 25, 45, and 75 Ω, are connected in series, and a 0.52-A current passes through them. What is (a) the equivalent resistance and (b) the potential difference across the three resistors?

52. A wire whose resistance is R is cut into three equally long pieces, which are then connected in parallel. In terms of R, what is the resistance of the parallel combination?

58. Find the equivalent resistance between points A and B in the drawing.

