

Section: Monday / Tuesday
(circle one)

Name: _____
Partners: _____

Total: /40

PHYSICS 107 LAB #3: WAVES ON STRINGS

Equipment: Function generator, amplifier, driver, elastic string, pulley and clamp, rod and table clamp, 2-meter stick, "wire 3" fishing line, scale, oscilloscope, 2 Male BNC – Male RCA adapters, , BNC cable, 1 BNC T, 1 male and 1 female BNC – Banana adapter, 2 Alligator clips, 2 Banana cables, sonometer with large hanging mass if need be, Magnet, Magnet stand, scale, guitar pick, violin bow, rubber mallet, pre-cut "2m" elastic and fishing line.

In the last section we use mock-up electric guitars to explore the effect of different attacks and pick-up location. If you have an electric guitar of your own, feel free to bring it.

OBJECTIVES

1. To observe the phenomenon of resonance and standing waves on strings and for sound waves.
2. To understand how the properties of the string (density and tension) affect the wave speed.
3. To understand how the wave properties of speed, wavelength, and frequency are related.
4. To explore the effects of different attacks and pick-up locations on the tonal qualities as heard and seen.

READINGS

To prepare for this lab, you should read the following sections of the text: Sections 7.4 and 10.1.

OVERVIEW

From pianos to electric guitars, properties of a vibrating string are central to a whole family of instruments. We will quantitatively study the relationship between the tension in a string and its fundamental frequency of vibration, and the relationship between harmonics of a fundamental frequency. We will qualitatively explore how the mix of harmonics is affected by different locations of the "pick-up" (as in an electric guitar's) and different "attacks" (pluck vs. struck, here vs. there).

The speed of a traveling wave is the rate at which a crest travels. The wave speed, v , is related to its frequency, f , and wavelength, λ , by

$$v = f\lambda.$$

This speed depends on the medium in which the wave is traveling.

The theoretical value for the speed of a wave transmitted along a string is

$$v = \sqrt{\frac{T}{\mu}},$$

where T is the tension in the string and μ is the string's mass per length (m_{st}/L).

When there is a standing wave on a string, the wave crests don't appear to travel along the length of the string. Instead, points of no displacement (nodes) stay put, and the crests (antinodes) oscillate between maximum and minimum. A simple example is people swinging a jump rope: the ends hardly go anywhere (nodes) while the rope in the middle swings around (antinode). Standing waves occur when the right number of wavelengths "fit" into the available length of medium. For a string anchored at both ends, this means that the two ends must be nodes, so an integer number of half wavelengths fit along the length of the string, that is,

$$L = n \frac{\lambda}{2} \text{ where } n = 1, 2, 3, \dots$$

When the string of an instrument is played, all members of the harmonic family of vibrations can be excited (f_1, f_2, f_3, \dots)¹; initially, even some vibrations *not* in this family are produced (but they die out quickly.) The relative strengths of each of these simultaneous vibrations determine the timbre of the sound produced. A performer can manipulate the mix of frequencies by varying where along the length of the string it is played, where it is picked-up (for an electric guitar), and the nature of the attack – sharp pluck, soft strum, or constant bowing. Specifically, of all the vibrations excited when a note is played, the longest wavelength / lowest frequency vibrations tend to be most strongly represented in a tone; however, there's a secondary emphasis on vibrations that have anti-nodes where you strike/pluck/bow the string; the electric pick-up only senses the motion of the string at its location and so emphasizes/deemphasizes vibrations with antinodes/nodes at that location; and the sharper the attack (in time and space), the more high-frequency / short-wavelength components are emphasized.

PART ONE: Simulation

In the simulation, you'll explore how the wave speed, v , changes as you change the string's tension, F_T , the wave's amplitude, and the wavelength, λ .

1. If it's not already open, from the desktop, launch "PhET Simulations;" through the yellow warning bar at the top of the browser allow blocked content; click the orange "Play with Sims;" through the Physics menu at the left, select "Waves and Sound"; then select the "Waves on a String" simulation; finally, click on "Run Now!"

¹ In real instruments, higher and higher frequency components tend to be sharper and sharper, but this is still a pretty good approximation.

2. **Tension and Wave Speed.** Wiggle the end of the string and vary the tension to qualitatively observe the effect of tension on wave speed. As the tension is *increased*, the wave speed:

/1 pt decreases / increases / stays the same (circle one).

Does your qualitative observation agree or disagree with the equation for the wave speed (see page 1)? Explain.

/2 pts

3. **Amplitude and Wave Speed.** Wiggle the string to send down two pulses of very different amplitudes chasing each other, one large and one small. What effect does amplitude have on wave speed?

/1 pt

4. **Wave Speed and Wavelength.** Now switch from “Manual” to “Oscillate” and observe the effect on wavelength of varying tension (and therefore wave speed). As the wave speed increases, the wavelength:

decreases / increases / stays the same (circle one).

/1 pt

Does your qualitative observation agree or disagree with the equation for the wave speed? Explain. (Hint: The frequency remains constant.)

/2 pts

PART TWO: Experimentation - Measuring Wave Speed

Now, you'll experimentally determine the wave's speed, v , from its frequency, f , and wavelength, λ . For this part, the tension will be held constant.

1. The setup of the string and driver will be similar to that pictured below.

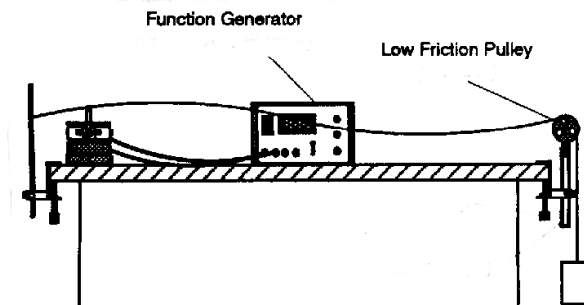

2. Hang 200 grams on the end of the string and start with a frequency down around 10 Hz (ask your instructor to help you get the function generator started.) Gradually increase the frequency until the amplitude of the

wave on the string increases dramatically indicating that you have reached a resonance. You should increase and decrease the frequency to find the value that gives the largest amplitude.

- Find four resonances and measure the distances between consecutive nodes to fill in the first *two* columns in the table below. Also draw the shape of each standing wave below the table (the first one's drawn for you.) Note: it can be tricky getting a good measurement when the string only makes one hump (just one node at each end), so take your measurements for more interesting patterns.

# of bumps	Frequency (Hz)	Distance between nodes (m)	Wavelength (m)	Speed of wave (m/s)
2				
3				
4				
5				

/4 pts

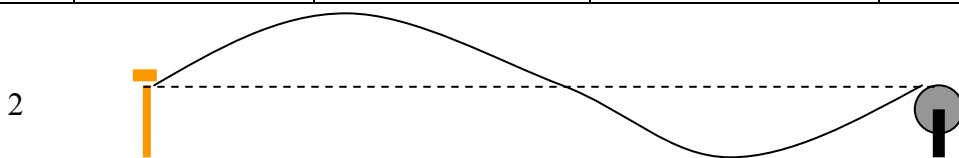

/3 pts

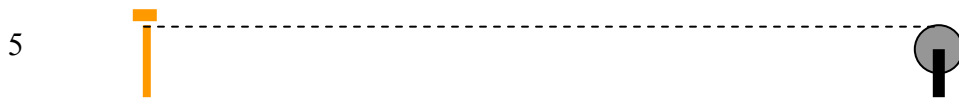
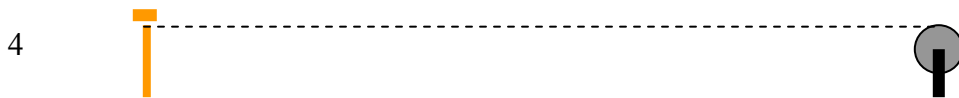
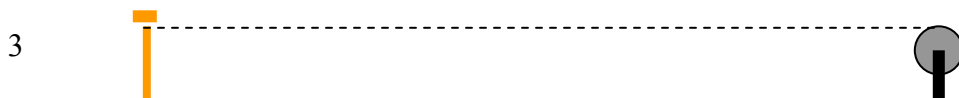

- Calculate the wavelength and speed for each of the standing waves to complete the table above. Show your first calculation.

/2 pts

5. Take the average of the speeds that you have found.

$$u_{\text{avg}} = \underline{\hspace{2cm}} \text{ m/s}$$

Now you'll compare this speed with that theoretically predicted, given the string's tension, T , and mass-per-length μ .

1. Since the 200 gram mass hung in equilibrium at the end of the string, the force the string provided, the Tension, is equal to the force the Earth provided, the weight. So, $T = m_h * 9.8 \text{ m/s}^2$.

$$T = \underline{\hspace{2cm}} \text{ N (1N = 1kg m/s}^2\text{)}$$

2. Determine the mass per unit length of the string *while it is stretched* by the 200 gram hanging mass. (Only include the mass of the string, not the mass that is stretching it.) To measure the stretched length, L , hold the unloaded string by its midpoint, hang the 200 gram mass off one end, and measure that half's stretched length and double it. See illustration.

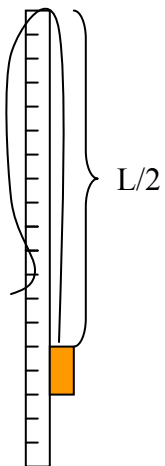

/2 pts

$$L = \underline{\hspace{2cm}}$$

$$m_{\text{st}} = \underline{\hspace{2cm}}$$

$$\mu = m_{\text{st}}/L = \underline{\hspace{2cm}}$$

3. Now, use the theoretical relation between the tension, this mass density, and the wave speed (given in the Overview section on the first page) to determine a theoretical value for the wave speed. Recall that when a 200 g mass hangs stationary from the string, the tension in the string must perfectly balance the mass's weight ($T = w = m * 9.8 \text{ m/s}^2$, where mass is in kg's.)

/1 pt

/2 pts

Question: Hopefully the theoretical value you've just calculated is quite similar to the one you more directly determined on the previous page. What is the percent difference between the two?

$$\% \text{ difference} = \left(\frac{v_{\text{avg}} - v_{\text{theory}}}{v_{\text{theory}}} \right) \cdot 100 =$$

PART THREE: Experimentation - Wave Speed versus Tension

Now, you'll vary the tension and determine how the wave's speed changes.

1. Since the flexible string is a little *too* flexible for our purposes, you'll use the fishing line for the next part. The first task is to determine the mass per unit length of the string. (Note that this string hardly stretches at all, so you won't have to hang a mass from it when measuring its length.)

$$L = \underline{\hspace{2cm}}$$

/2 pts

$$m_{\text{st}} = \underline{\hspace{2cm}}$$

$$\mu = m_s/L = \underline{\hspace{2cm}}$$

2. Set up the fishing line as you'd had the string – attached to one rod, clipped to the driver, and hanging over the pulley.
3. For hanging masses of 100 g, 200 g, 300 g, 400 g, and 500 g, adjust the function generator's frequency to find a standing-wave pattern with a few nodes (not too many since high-frequency near-resonance patterns can be deceptive; you need not choose the same pattern with each hanging mass. (Note that the amplitude of the standing waves will not be so large with this string.) Record the frequency and distance between nodes in the table on the next page. Calculate the tension, speed, and speed squared to complete the table.

/3 pts

Mass (kg)	Tension (N) $M \cdot 9.8 \text{ m/s}^2$	Freq. (Hz)	Distance between nodes (m)	v (m/s)	v ² (m ² /s ²)

4. Graph the square of the speed (v²) versus the tension (T) below. Be sure to label the axes.

/3 pts

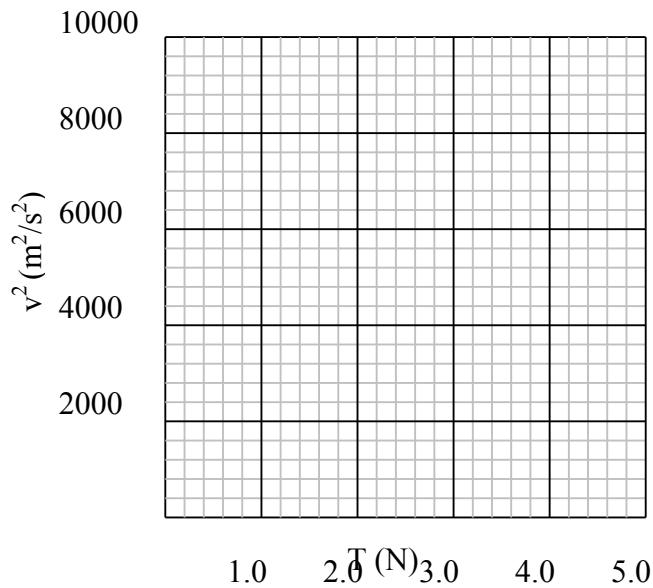

5. Calculate the slope of a line that fits your data (use two distant points on your best-fit straight line; they needn't be actual data points.) Show your work and write your result below.

/2 pts

slope = _____ $\frac{\text{m}}{\text{kg}}$ $\left(\frac{\frac{\text{m}^2}{\text{s}^2}}{\text{N}} = \frac{\frac{\text{m}^2}{\text{s}^2}}{\text{kg} \cdot \frac{\text{m}}{\text{s}^2}} = \frac{\text{m}}{\text{kg}} \right)$

6. For comparison's sake, calculate the theoretically-expected value of the slope. For this, recall that the equation of a line has the form $Y = (\text{slope})X + (\text{intercept})$; on your plot, v^2 plays the role of Y while T plays the role of X. Now, squaring the theoretical relation on page 1 gives $v^2 = \left(\frac{1}{\mu}\right)T$, so the factor in brackets is playing the role of *slope* (this equation predicts an *intercept* of 0.)

/2 pts

/1 pt

$$\text{slope}_{\text{theory}} = \left(\frac{1}{\mu}\right) = \text{_____ m/kg}$$

Question: How does the value of the plot's slope compare with the theoretically expected value (% difference)? If they differ by more than 20%, find and fix your mistake.

/2 pts

% difference =

PART FOUR: Experimentation – Attack and Pick-Up Effects

You will now play varying the location and sharpness of your ‘attack’ as well as the location of the electric pick-up to see and hear how they affect the string’s vibrations.

PRINCIPLE OF OPERATION

This is basically how an electric guitar works: As shown below, you’ll use a steel wire that passes by a magnet. When you pluck the wire, the electrons in it feel a force due to their motion (vibration along with the wire) in the presence of the magnet. This force causes them to vibrate back and forth along the length of the wire, in synch with the wire’s vibrations up and down. The oscilloscope picks up on the electrical oscillation. The important thing is that this signal detected by the oscilloscope and sent to the speaker is *in synch with the vibrations of the segment of the wire right by the magnet.*

SET-UP (Most of this will already be done for you)

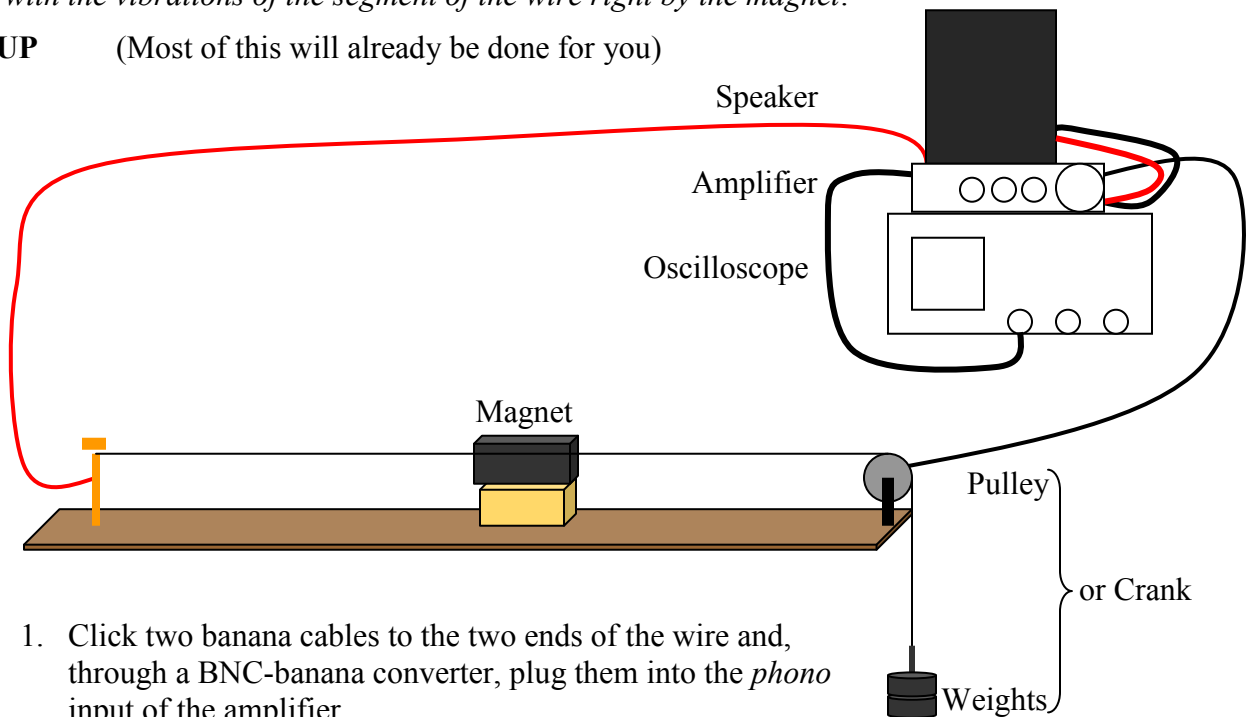

1. Click two banana cables to the two ends of the wire and, through a BNC-banana converter, plug them into the *phono* input of the amplifier.
2. Then, through another BNC-banana converter, use banana cables to plug the speaker into the corresponding *speaker* output of the amplifier.
3. Also jump another set of banana cables from the *speaker* output to the o’scope’s channel 1 (using yet another BNC-banana converter.)
4. To keep the magnet (the stronger, the better) from attaching itself to the steel guitar string, set it on something iron/steel, like one of the 1kg masses.

EXPERIMENT

1. **Vary Attack. Vary Attack.** “Playing” the string at the *same point* along its length, vary *how* you “play” the string: ex. tap with your finger, strike with a mallet, sharply pluck with a your fingernail, or a draw with a bow (it’s best to very lightly draw a bow perpendicularly across the string.) Describe how the sound and the pattern on the oscilloscope differs for the different attacks & what this says about the mixes of frequencies produced? Some useful adjectives for describing the sounds might be ‘bright’, ‘twangy’, ‘dull’, and ‘warm.’

/2 pts

2. **Vary Location of Attack.** Sharply pluck the string at different points along its length. Again, describe how the sound and the pattern on the oscilloscope change & what this say about the mixes of frequencies produced?

/2 pts

3. **Vary Location of Pick-Up.** Sharply pluck or bow the string *in the middle* and *move the magnet* to different points along its length (this is similar to locating an electric guitar’s pick-ups at different points, you may be aware that electric guitars have two sets of pick-ups for this vary reason). Describe how the pattern on the oscilloscope and what you hear over the speaker changes & what this say about the mixes of frequencies in the electric signal in the wire?

/2 pts